

CFX HELPS IN ENSURING SAFE POWER PLANT

by R. Buettner, R. Walterskötter and H. Schmidt, Framatome ANP GmbH TGT1, Germany

The safety aspects of gas turbine power plant have become a major concern around the world, and many local safety authorities now require the analysis of leakage in the gas supply of turbines as a part of the approval to operate plants. Safety is our speciality at the Technical Centre of Framatome ANP GmbH. Capitalising on our extensive expertise in power plant technology, we offer a multi-disciplinary approach to consulting with, among others, competence in material technologies and thermal fluid dynamics.

Over the years, we have gained comprehensive experience in the safety aspects of gas turbine power, with the analysis of many different plants

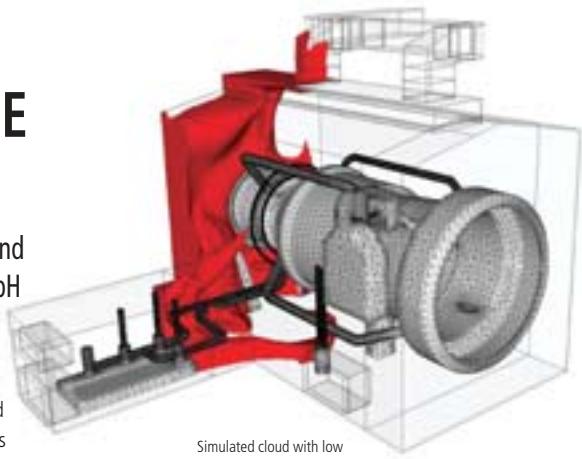

Simulated cloud with low methane concentration.

of the components inside the enclosure, with additional grid refinement in the vicinity of the gas leakage. Some smaller details were simplified, for example, the silencer and the perforated plate at the roof duct were modelled as regions with resistance coefficients, and the front gas turbine pillars were modelled as thin surfaces. We set the gas leak to be a methane jet with an initial speed of nearly Mach one. For turbulence modelling, we used the standard $k-\epsilon$ model with logarithmic wall functions and buoyancy forces to account for the heat transfer between the turbine surfaces and the flow.

These CFD calculations showed that the volume of the methane cloud at the critical concentration was smaller than the stipulated maximum value. However, they also made clear that geometric constraints around the leakage site were leading to stagnation and poor mixing, and that higher methane concentrations, though still below the critical value, could be expected in these regions. Improvements to the efficiency of the ventilation were then studied, and based on these results we could optimise the positions of the methane detectors, leading to a plant that exceeds the Health & Safety requirements.

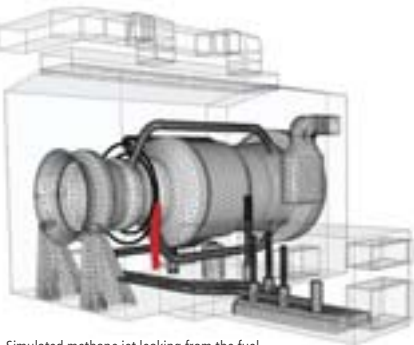

Simulated methane jet leaking from the fuel entry system of the gas turbine acoustic enclosure.

and designs. In a recent project, we looked at reducing hazards due to hypothetical leakages in the fuel gas system of a turbine. The turbine was located in an acoustic enclosure which employed forced-convection ventilation to diffuse any gas leakage to below a specified concentration level. The specified level is defined as "under control" by the local Health & Safety department. If this condition is fulfilled, the risk of an explosion causing significant damage or injury can be considered as controlled.

We needed to determine that, should a leak occur in the fuel system, gas would be detected before it reached the specified concentrations. We decided to use CFX-5 for the analysis, its automatic mesh generation capability speeding up the meshing work enormously. We accurately represented most

Secondary flow patterns in a cross section (bottom view), shaded by methane concentration, showing the regions where the gas is entrained.

